



Shyang Yun Tools Co., Ltd.

No. 161, Sitou Rd., Shengang Dist., Taichung City 42953, Taiwan
Tel: +886-4-25631268 Fax: +886-4-25632678

EC DECLARATION OF CONFORMITY

FOR NON-ANNEX IV MACHINERY

IN ACCORDANCE WITH

**MACHINERY SAFETY DIRECTIVES
2006/42/EC**

WE, SHYANG YUN TOOLS CO., LTD. HEREBY CERTIFY THAT THE MACHINERY DESCRIBED BELOW CONFORMS WITH THE ESSENTIAL HEALTH AND SAFETY REQUIREMENTS OF MACHINERY SAFETY DIRECTIVES 2006/42/EC ON THE APPROXIMATION OF THE LAWS OF THE MEMBER STATES RELATING TO THE SAFETY OF MACHINERY,

- 82541 1/2"DR. AIR IMPACT WRENCH
- 82542 1/2"DR. AIR IMPACT WRENCH
- 82563 3/4"DR. AIR IMPACT WRENCH
- 82585 1"DR. AIR IMPACT WRENCH
- 82585S 1"DR. AIR IMPACT WRENCH
- 82586 1"DR. AIR IMPACT WRENCH
- 82586L 1"DR. AIR IMPACT WRENCH

AND COMPLY WITH THE PROVISIONS SET OUT IN THE FOLLOWING EUROPEAN STANDARD:

- ISO 12100:2010 (RISK ASSESSMENT & RISK REDUCTION)
- ISO 11148-6:2010 (SAFETY REQUIREMENTS)
- ISO 15744:2002 (NOISE LEVEL)
- ISO 28927-2:2009 (VIBRATION LEVEL)



DATE OF ISSUE: 10 April 2012

NAME: Mr. Tom Lin

POSITION/TITLE: Manager

SIGNATURE: Tom Lin



Shyang Yun Tools Co., Ltd.
 No. 161, Sitou Rd., Shengang Dist., Taichung City 42533, Taiwan
 Tel: +886-4-25631268 Fax: +886-4-25632678

Specifications

Model	Square Drive	Std. Bolt size		Free Speed	MAX. Torque		Overall Length		Air Inlet	Air Hose	Avg. Air Consumption		Net Weight		Sound Pressure Level	Sound Power Level	Sound Pressure Level	Sound Uncertainty (K)	Vib. Level	Vib. Uncertainty (K)
	inch	inch	mm	R.P.M	ft-lb	N.m	inch	mm	PT	I.D	cfm	L/min	lbs	kgs	dB(A)	dB(A)	dB(C)	dB	m/s ²	m/s ²
82541	1/2	5/8	M16	8,000	400	542	7-1/8	180	1/4	3/8	4.2	119	5.58	2.56	94	105	118	3	7.0	1.2
82542	1/2	5/8	M16	8,000	600	813	7-21/64	186	1/4	3/8	4.2	119	5.58	2.56	97	108	112	3	8.0	1.3
82563	3/4	1	M25	6,500	750	1016	9-7/32	234	1/4	3/8	7	198	10	4.55	97	108	121	3	8.3	1.3
82585S	1	1-1/2	M38	4,000	1800	2439	11-15/16	303	1/2	3/4	12	340	23.41	10.62	104	115	121	3	19.32	2.4
82585	1	1-1/2	M38	4,000	1800	2439	20	518	1/2	3/4	12	340	27.53	12.5	104	115	121	3	19.32	2.4
82586	1	1-27/64	M36	4,000	1500	2033	12-13/32	315	1/2	3/4	11	311	21.12	9.06	104	115	119	3	15.1	2.0
82586L	1	1-27/64	M36	4,000	1500	2033	21	533	1/2	3/4	11	311	24.45	11.1	104	115	119	3	15.1	2.0

FORCE[®]

3/4" SQ. DR. IMPACT WRENCH

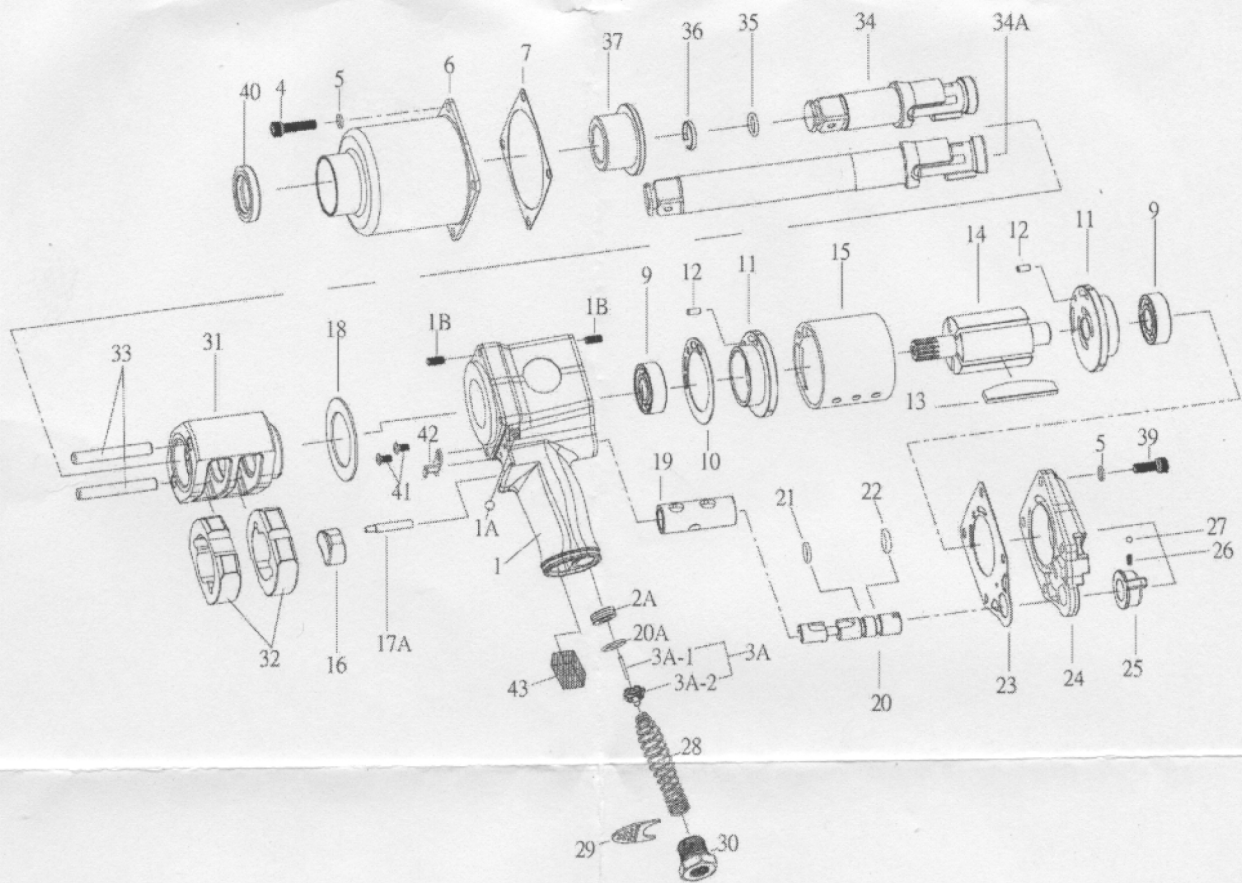

FORCE[®] No. 82563

INDEX NO.	DESCRIPTION	REQ'D NO.	INDEX NO.	DESCRIPTION	REQ'D NO.
★ 1	Housing Assembly (incl. 1A, 1B (8), 19)	1	21	O-Ring	1
1A	Steel Bal	2	22	O-Ring	1
1B	Heli-coil	8	23	Gasket	1
2A	Throttle Valve Sea	1	24	Backhead	1
★ 3A	Throttle Valve Assembly (incl. 3A-1, 3A-2)	1	25	Reverse Valve Knot	1
3A-1	Throttle Valve Pir	1	26	Spring	1
3A-2	Throttle Valve	1	27	Steel Bal	1
4	Screw	4	28	Spring	1
5	Spring Washer	8	29	Exhaust Deflector	1
6	Hammer Case	1	30	Air Inlet	1
7	Gasket	1	31	Hammer Frame	1
9	Ball Bearing	2	32	Hammer	2
10	Gasket	1	33	Hammer Pin	2
11	End Plate	2	34	Standard Anvil (for KI-23	1
12	Spring Pin	2	34A	6" Extended Anvil (for KI-23-6	1
13	Rotor Blade	5	35	O-Ring	1
14	Rotor	1	36	Socket Retaine	1
15	Cylinder	1	37	Bushing	1
★ 16	Trigger Assembly (incl. 17A)	1	39	Screw	4
17A	Trigger Pin	1	40	Oil Seal	1
18	Washer	1	41	Screw	2
19	Reverse Valve Bushing	1	42	Trigger Retaine	1
20	Reverse Valve	1	43	Muffler Element	1
20A	O-Ring	1	TK	Tune-Up Kit (7.9(2), 10, 13(5), 20A, 21, 22, 23, 26, 27, 28, 35, 36, 43)	

★ Must be Purchased in Assembly Set

PA2-00023-1 20090416R2



Shyang Yun Tools Co., Ltd.

No. 161, Sitou Rd., Shengang Dist., Taichung City 42953, Taiwan
http://www.force.com.tw

FORCE SUPER DUTY AIR IMPACT WRENCH · RATCHET WRENCH · SCREWDRIVER



Read and understand the owner's manual and labels affixed to the tool. Learn its application and limitations as well as the specific potential hazards peculiar to this tool.

A. OPERATION GUIDES

TIPS FOR USE :

(Safety Regulations while using FORCE brand Air Impact Wrenches)

1. AIR PRESSURE :

Always use the clean and dry air to operate the tool at 90 psi(6.2 bar) & do not operate exceed maximum-working-air pressure-at 90psi(6.2 bar)as recommended.

2. AIR LINE

Use a fitting air hose for connection between the compressor & tools.

The compressed air is cooled and its water content would be sorted when the air blow out from the compressor.

Part of the water could be compressed in the pipe and could permeate into the tool's mechanism to cause mechanical failures.

It would be strongly recommended to install an air filter, moistureseparator, regulator and lubricator among the air supply and the air tools.

3. AIR HOSE

Before connecting the hose to air tools ,please clean firstly the hoses with a blowout of compressed air. This will prevent both moisture and dust contented within the hose from entering the tools and causing the possible rust and malfunction.

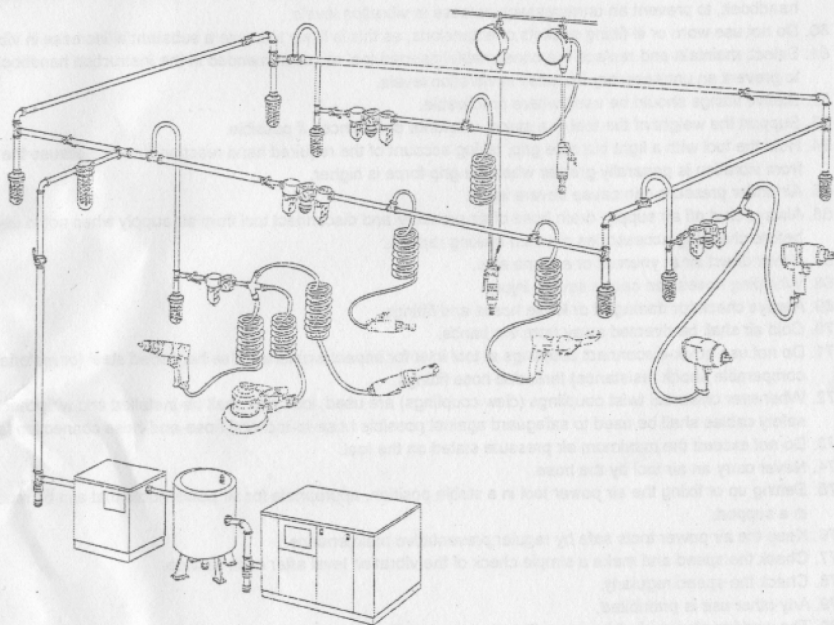

Read and understand the owner's manual and labels affixed to the tool. Learn its application and limitations as well as the specific potential hazards peculiar to this tool.



B. OPERATIONAL METHOD

1.The on/off device is designed inside or outside of the grip. It is a "plug-and-run" type device. This tool will stop operation/rotation in a few seconds after relieving the level control.

2.These accessories or attachments are recommended for use with your FORCE tool specified in this manual. The use of any other accessories or attachments might present a risk of injury to persons. Only use accessory or attachment for its stated purpose.

3.The speed set up device is indicated by an arrow mark and intergraded with an indication either marked by " H"(high) and "L"(low) or by "+"(high) and "-"(low), rotating the knob to desired speed.

4.Torque Regulator

To set up the torque by using the knob which is indicated by the numbers. Higher number indicates higher torque output setting.

5.Rotating Direction

Be sure the rotation direction before operating this tool. The "F" point out the direction of forward and the "R" indicates reserve direction. Forward direction is defined as clockwise direction seen from the operator's position.



C. MAINTENANCE & REPAIRS

1.Lubrication

Before connecting the air hose, it should apply 4 to 5 drops of #60 spindle oil at air inlet. The repeat oiling after 3 to 4 hours operation will be necessary.

2.Fastening of parts

Do the regular check if all the connecting parts are fastened securely properly . It is necessary to go through this check daily before starting your work.

3.Cleanness

Dusty and oiling surface on the handle will infected the grip which caused to the reaction torque. Clean the handle with dry clothing is strongly recommended before operation this tool.

4.Storage

Put the tool in dry and clean environment. If the tool shall not to be used for a period of time , the residual moisture inside of the instrument could cause the rust. Before storing, oil the instrument at air inlet with spindle oil and operate it for a short period is strongly recommended.

5.Repairs

Do make use of the spare parts for all the maintenance and repairing job.

Do not invent or make any unnecessary temporary repairs. Major service of maintenance and repairs should be only carried out by well-trained persons or FORCE of its own authorized service representatives.

Make sure the free speed after each service.



D.DISPOSAL

Following is the national legislation of waste disposal. Never dispose of the air tool into fire.

Separate collection!! This product must not be disposed with normal household waste.

Warranty

All of FORCE serial pneumatic tools are provided with complete after service and product warranty to the product that manufactured by Shyang Yun Tools Co., Ltd. and sold by its worldwide authorized dealers. FORCE professional air tools, unless otherwise specified are unconditionally guaranteed against defects in materials and workmanship for the life of tool, excluding any other inappropriate operation, modification or repair.

FORCE will repair or replace the tool that fails to give satisfaction service on the condition that tool has not been abused or modified and that it is returned to authorized warranty FORCE dealer, If there is a defective product claim of FORCE, please contact the FORCE's authorized sales /service representatives.



Shyang Yun Tools Co., Ltd.

No. 161, Sitou Rd., Shengang Dist., Taichung City 42953, Taiwan
http://www.force.com.tw

FORCE SUPER DUTY AIR IMPACT WRENCH · RATCHET WRENCH · SCREWDRIVER



Read and understand the owner's manual and labels affixed to the tool. Learn its application and limitations as well as the specific potential hazards peculiar to this tool.

WARNING

1. For multiple hazards, read and understand the safety instructions before installing, operating, repairing, maintaining, changing accessories on, or working near the air power tool. Failure to do so can result in serious bodily injury.
2. Only qualified and trained operators should install, adjust or use the air power tool.
3. Do not modify this air power tool. Modifications can reduce the effectiveness of safety measures and increase the risks to the operator.
4. Do not discard the safety instructions; give them to the operator.
5. Do not use the air power tool if it has been damaged.
6. The employer/user shall contact the manufacturer to obtain replacement marking labels when necessary.
7. Failure of the workpiece, of accessories or even of the inserted tool itself can generate high-velocity projectiles.
8. Always wear impact-resistant eye protection during the operation of the air power tool. The grade of protection required should be assessed for each use.
9. Ensure that the workpiece is securely fixed.
10. Entanglement hazards can result in choking, scalping and/or lacerations if loose clothing, personal jewellery, neckware, hair or gloves are not kept away from the tool and accessories.
11. Gloves can become entangled with the rotating drive, causing severed or broken fingers.
12. Rotating drive sockets and drive extensions can easily entangle rubber-coated or metal-reinforced gloves.
13. Do not wear loose-fitting gloves or gloves with cut or frayed fingers.
14. Never hold the drive, socket or drive extension.
15. Keep hands away from rotating drives.
16. The use of the tool can expose the operator's hands to hazards including crushing, impacts, cuts and abrasions and heat. Wear suitable gloves to protect hands.
17. Operators and maintenance personnel shall be physically able to handle the bulk, weight and power of the tool.
18. Hold the tool correctly; be ready to counteract normal or sudden movements and have both hands available.
19. Maintain a balanced body position and secure footing.
20. It is recommended to use a suspension arm whenever possible.
21. Reaction bars are recommended for angle nutrunners.
22. It is recommended to use a means to absorb the reaction torque above 4 N·m for straight tools, above 10 N·m for pistol-grip tools.
23. Release the start-and-stop device in the case of an interruption of the energy supply.
24. Use only lubricants recommended by FORCE's authorized sales or service representatives.
25. Do not use in confined spaces and beware of crushing hands between tool and workpiece, especially when unscrewing.
26. Tool and/or accessories may briefly continue their motion after trigger is released.
27. Keep others a safe distance from your work area, or ensure they use appropriate personal protective equipment.
28. When using a power tool for the operator can experience discomfort in the hands, arms, shoulders, neck, or other parts of the body.
29. While using an air power tool, the operator should adopt a comfortable posture whilst maintaining secure footing and avoiding awkward or off-balanced postures.
30. While using an air power tool, the operator should change posture during extended tasks, which can help avoid discomfort and fatigue.
31. If the operator experiences symptoms such as persistent or recurring discomfort, pain, throbbing, aching, tingling, numbness, burning sensations or stiffness, these warning signs should not be ignored. The operator should tell the employer and consult a qualified health professional.
32. Disconnect the air power tool from the energy supply before changing the inserted tool or accessory.
33. Do not touch sockets or accessories during impacting, as this increases the risk of cuts, burns or vibration injuries.
34. Use only sizes and types of accessories and consumables that are recommended by FORCE's authorized sales or service representatives.
35. Use only impact wrench rated sockets in good condition, as poor condition or hand sockets and accessories used with impact wrenches can shatter and become a projectile.
36. Slips, trips and falls are major causes of workplace injury.
37. Be aware of slippery surfaces caused by the use of the tool and also of trip hazards caused by the air line or hydraulic hose.
38. Proceed with care in unfamiliar surroundings. Hidden hazards, such as electricity or other utility lines, can exist.
39. The air power tool is not intended for use in potentially explosive atmospheres and is not insulated against coming into contact with electric power.
40. Make sure there are no electrical cables, gas pipes, etc., that can cause a hazard if damaged by use of the tool.
41. Dust and fumes generated when using air power tools can cause ill health (for example, cancer, birth defects, asthma and/or dermatitis); risk assessment and implementation of appropriate controls for these hazards are essential.
42. Risk assessment should include dust created by the use of the tool and the potential for disturbing existing dust.
43. Direct the exhaust so as to minimize disturbance of dust in a dust-filled environment.
44. Where dust or fumes are created, the priority shall be to control them at the point of emission.
45. All integral features or accessories for the collection, extraction or suppression of airborne dust or fumes should be correctly used and maintained in accordance with the manufacturer's instructions.
46. Use respiratory protection in accordance with employer's instructions and as required by occupational health and safety regulations.
47. Unprotected exposure to high noise levels can cause permanent, disabling, hearing loss and other problems, such as tinnitus (ringing, buzzing, whistling or humming in the ears).
48. Risk assessment and implementation of appropriate controls for these hazards are essential.
49. Appropriate controls to reduce the risk may include actions such as damping materials to prevent workpieces from "ringing".
50. Use hearing protection in accordance with employer's instructions and as required by occupational health and safety regulations.
51. Operate and maintain the air power tool as recommended in the instruction handbook, to prevent an unnecessary increase in noise levels.
52. If the assembly power tool for threaded fasteners has a silencer, always ensure it is in place and in good working order when the assembly power tool for threaded fasteners is operating.
53. Select, maintain and replace the consumable/inserted tool as recommended in the instruction handbook, to prevent an unnecessary increase in noise.
54. For recommended interface dimensions for spindles and drive adapters to help reduce vibrations, please contact the FORCE's authorized sales or service representatives.
55. Exposure to vibration can cause disabling damage to the nerves and blood supply of the hands and arms.
56. Keep the hands away from the sockets.
57. Wear warm clothing when working in cold conditions and keep your hands warm and dry.
58. If you experience numbness, tingling, pain or whitening of the skin in your fingers or hands, stop using the assembly power tool for threaded fasteners, tell your employer and consult a physician.
59. Operate and maintain the assembly power tool for threaded fasteners as recommended in the instruction handbook, to prevent an unnecessary increase in vibration levels.
60. Do not use worn or ill-fitting sockets or extensions, as this is likely to cause a substantial increase in vibration.
61. Select, maintain and replace the consumable/inserted tool as recommended in the instruction handbook, to prevent an unnecessary increase in vibration levels.
62. Sleeve fittings should be used where practicable.
63. Support the weight of the tool in a stand, tensioner or balancer, if possible.
64. Hold the tool with a light but safe grip, taking account of the required hand reaction forces, because the risk from vibration is generally greater when the grip force is higher.
65. Air under pressure can cause severe injury.
66. Always shut off air supply, drain hose of air pressure and disconnect tool from air supply when not in use, before changing accessories or when making repairs.
67. Never direct air at yourself or anyone else.
68. Whipping hoses can cause severe injury.
69. Always check for damaged or loose hoses and fittings.
70. Cold air shall be directed away from the hands.
71. Do not use quick-disconnect couplings at tool inlet for impact wrenches. Use hardened steel (or material with comparable shock resistance) threaded hose fittings.
72. Whenever universal twist couplings (claw couplings) are used, lock pins shall be installed and whipcheck safety cables shall be used to safeguard against possible hose-to-tool and hose-and-hose connection failure.
73. Do not exceed the maximum air pressure stated on the tool.
74. Never carry an air tool by the hose.
75. Setting up or fixing the air power tool in a stable position, appropriate for air power tools that can be mounted in a support.
76. Keep the air power tools safe by regular preventative maintenance.
77. Check the speed and make a simple check of the vibration level after each service.
78. Check the speed regularly.
79. Any other use is prohibited.
80. The working places shall keep ventilated, clean and illuminated.